

**SWEENEY**

**AIRCRAFT ASSEMBLY &  
MAINTENANCE TOOLS**

COMMERCIAL AND MILITARY



**ENERPAC** 

# **The Right Tool Makes All the Difference**

Enerpac tools are put to work under the most intense and demanding conditions. That's why we never compromise. So you can rely on quality and precision every time, giving you the safest and most efficient path to increase productivity.

As a global market leader in high pressure hydraulic tools, controlled force products and solutions for precision positioning of heavy loads, Enerpac products have moved some of the largest structures on earth. They are the industry-standard in aerospace, infrastructure, manufacturing, mining, oil & gas, power generation and much more.

**Elite tools. For elite professionals.**

# Commercial and Military Applications

**The Sweeney portfolio has served the aerospace market for nearly 80 years with specialized aircraft and engine maintenance tools.**

By working in close partnership with the world's leading Original Equipment Manufacturers (OEMs), solutions are developed using a needs-first approach to product innovation. Designing for customer needs and the user experience results in the most advanced tools for critical assembly applications.

Sweeney products are built to last. Our engineering and quality standards ensure our tools never fail when used as intended. Sweeney products are designed for use on the following engine models, however we can design and build customized tooling for any challenging application; see page 9 for further details.

## Commercial

- High torque requirements and tooling used for assembly and teardown on the following turbofan engines:
  - CFM56
  - V2500
  - CF6
  - GE90
  - GENx
  - JT8D
  - JT9D
  - PW2000
  - PW4000
  - AE2100
  - RB211
  - TRENT

## Military

- High-torque requirements for turbofan engines:
  - Pratt F100 on the F-15 and F-16
  - GE F110 on the F-16
  - GE F404 on the F-18
  - GE J85 on the F-5 and T-38
- Propeller removal assemblies on turboprop engines:
  - T56 on the C-130, E-2, & P3 Orion
- Rotor hoists and ground support equipment for:
  - T55 on the CH-47 Chinook
  - T64 on the CH-53 Super Stallion
  - T700 on the Apache, Black Hawk, Super Huey & Super Cobra

Sweeney products are proudly supplied to the US Government.  
DUNS: 557305146  
CAGE Code: 87641

ISO 9001 (Quality Management), ISO 14001 (Environmental Management) and OHSAS 18001 (Occupational Health and Safety).



Sweeney torque multipliers are the aerospace industry standard. These multipliers are used on aircraft both in the commercial and military world.

Sweeney aerospace torque multipliers are high ratio, multiple reduction gear mechanisms that provide a means for loosening and tightening threaded assemblies that demand very high torque values.

Each model is designed with an internal splined drive or square drive that connects to sleeve sockets specially designed for each application. Anchor pins are located on the back and/or front surfaces for versatility of anchoring.

At the heart of the Sweeney offering is the model SWE8200, the multiplier of choice for commercial and military applications up to 12000 ft-lbs (16262 Nm).

Specifications	UOM	SWE8105A <sup>▲</sup>	SWE8200 <sup>▲</sup> SWE8200DS * SWE8210 **	SWE8300C
Rated output capacity	in-lbs	36000	144.000	360.000
	ft-lbs	3000	12.000	30.000
	Nm	4067	16.262	40.675
Anchor pin center-to-center	in	10.5		
	mm	266,7		
Anchor pins	1" (25 mm) diameter, 1" (25 mm) long			
Weight	lbs	31	54	195
	kg	14.06	24.49	88.5
Length	in	14.94	17.91	32.75
	mm	379	455	832
Width	in	12.75	12.5	20.5
	mm	324	318	521
Height	in	6	7.53	9.88
	mm	152	191	251
Torque ratio		8:1	11.1:1	42:1
Input drive	3/4" (19 mm) square female			
Output drive	Internal spline, 43 teeth 8/16 pitch			

<sup>▲</sup> NSN Part numbers Model SWE8105A: 5120-00-406-3037, Model SWE8200: 5120-00-377-9652

\* Model SWE8200DS (double spline) also available

\*\*Digital read out

The model SWE8100 is no longer available. All SWE8100 torque multipliers should be replaced by the SWE8200.



Model SWE8105A



Model SWE8200/SWE8200 DS



Model SWE8210



Model SWE8300

# Models SWE8112B & SWE8111 and Torque Multiplier Accessories

For moderate to heavy-duty torque solutions, the Sweeney product portfolio offers a wide selection of accessories that increase ease and extend the range of applications.

Sweeney models SWE8112 and SWE8111 incorporate an automatic brake system that inhibits reverse torque from the multiplier's output being transferred to the multiplier's input drive. These models are also equipped with a primary input drive for high torque/low speed use, as well as a secondary input for low torque/high speed applications.

Specifications	UOM	SWE8112B <sup>▲</sup>	SWE8111E
Rated output capacity	in-lbs	600.000	1000.000
	ft-lbs	50.000	83.333
	Nm	67.791	112.985
Anchor pin center-to-center	in	15.25	22
	mm	387,35	558,8
Anchor pins		1" (25 mm) diameter, 1" (25 mm) long	1.5" (38 mm) diameter, 1" (25 mm) long
Weight	lbs	270	395
	kg	122,5	179
Length (including sling)	in	41.68	46.15
	mm	1059	1172
Width	in	24.45	29.45
	mm	621	748
Height	in	13.69	13.69
	mm	1348	348
Torque ratio		65:1	125:1
Input drive		3/4" (19 mm) square female	
Output drive		Internal spline, 43 teeth 8/16 pitch	

<sup>▲</sup> NSN Part numbers Model SWE8112B: 5120-00-222-5001

Slings are available for the SWE8100 and SWE8200 series of multipliers. These slings attach directly to the multipliers and aid in the lifting and positioning of the tools during use. Also available are work handles with extendible arms, which provide increased leverage, and ratchet adaptors, which turn a standard breaker bar into a ratchet.

Part No.	Description	Specification information
SWE81002	Sling	Used on models SWE8100 and SWE8200
SWE81046	Adaptor	Adapts splined multipliers to 2-7/8" (73 mm) female hex
SWE86511L	Socket	Allows customers to produce own sockets and power with Sweeney splined multipliers
SWE67	Ratchet Adaptor	Input: 3/4" (19 mm) square female Output: 3/4" (19 mm) square male
SWE63	Work Handle	Length: telescopes from 18"-30" (457,2 – 762 mm) Output: 3/4" (19 mm) square male

Note: For manual operation in applying torque, models SWE53, SWE63 and the SWE67 hand tools may be used with models SWE8200, SWE8111, SWE8112 and the SWE8300.



Model SWE8112



Model SWE8111



SWE81002 Sling

The Sweeney SWE8202 series provides additional multiplication to make difficult torque procedures even easier. Input torque is reduced by an additional 6.5:1 ratio.

## SWE8202A Pneumatic Torque Multiplier

The model SWE8202A Air Torque Multiplier is designed to provide controlled air operation of model SWE8105, SWE8200, SWE8111, SWE8112 and SWE8300 torque multipliers.

Specifications	UOM	SWE8202A
Maximum input air	psi	90
	bar	6,2
Output direct drive (1:1)	in-lbs	2256
	ft-lbs	188
	Nm	255
Output reduced speed drive (6.5:1)	in-lbs	15060
	ft-lbs	1255
	Nm	1661

### Weight

SWE8202-45A torque multiplier	lbs	11
	kg	5
SWE8202-90 gearbox & airmotor	lbs	11
	kg	5
SWE8106-90A air control kit	lbs	3
	kg	1,4
Model SWE8202A (total weight)	lbs	25
	kg	11,3

NSN part number for the SWE8202A: 5130-01-211-2188



Model SWE8202A with Model SWE8300

## SWE8202-290A Mechanical Torque Multiplier

The model SWE8202-290A provides controlled operation of model SWE8105A, SWE8200, SWE8111, SWE8112 and SWE8300 torque multipliers. The manually operated unit eliminates the need of reacting the input torque and holds torque through an anti-backlash device.

Specifications	UOM	SWE8202-290A
Output direct drive (1:1)	in-lbs	2256
	ft-lbs	188
	Nm	255
Output reduced speed drive (6.5:1)	in-lbs	15060
	ft-lbs	1255
	Nm	1661

### Weight

SWE8202-45A torque multiplier	lbs	11
	kg	5
SWE4600-285 Ratchet	lbs	4
	kg	1,81
SWE8202-290A (total weight)	lbs	17
	kg	7,7

NSN part number for the SWE8202-290A: 5120-01-364-9523



Model SWE8202-290A with Model SWE8200

The Sweeney Digital Torque Multiplier Series was developed to perform high tolerance bolt up and break out operations within the Aerospace, Industrial and Oil and Gas industries.

For increased control and operation, the torque multipliers within this series are equipped with a high resolution 7" display. During use, relevant measuring values appear on screen including torque, angle of turn, and graph depicting torque over time. Values appear in full color and large format type enabling the operator to easily view and interpret data. The icon based menu driven system is controlled using an ultra-sensitive touch screen that responds to input even when gloves are worn.

When an operation is complete, all data is stored on the device for future export through available USB port or through email when connected to WiFi. Each user can create a separate login profile to keep all recorded job data separate if needed.

## Features

- Output accuracies of +/- 0,4% full scale
- Ergonomic handles aid in positioning
- 7" full color high resolution monitoring screen
- Battery powered monitoring screen with 8hr run time
- Accurate digital angle of turn readings
- Available measuring units include Nm, Ncm, lb ft, lb in, oz in, kNm, klb ft, kg m, kg cm
- Forward and rear facing cameras for capturing pictures and video.

\* A base model tablet without WiFi and camera features is also available



Check monitoring screen with relevant torque operation values

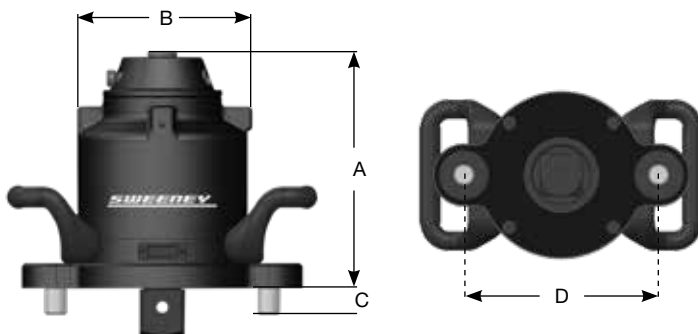

## Specifications

Part No.	Max Output		Max Input		Torque Ratio	Input Sq. Size	Output Sq. Size	Overload Protection	Anti-Backlash
	ft-lbs	Nm	ft-lbs	Nm					
<b>SWE8510D</b>	1000	1356	196	266	5,1:1	1/2"	3/4"	No	Yes
<b>SWE8550D</b>	5000	6780	189	256	26,5:1	1/2"	1-1/2"	Yes	Yes

## Dimensions

Part No.	A - Height		B - Width		C - Reaction Stick Out		D - Reaction Points		Weight	
	in	mm	in	mm	in	mm	in	mm	lb	kg
<b>SWE8510D</b>	5.1	129,5	4.4	112	0.53	13,5	3	76,2	14.5	6,6
<b>SWE8550D</b>	7.6	192,9	5.6	142,3	0.86	21,9	7	177,8	32	14,5

Providing a safe, controlled, cost effective way to rotate turbine engines during borescope inspection.

## Features

- Borescope operator controls turbine rotation
- Automatic blade counting
- Flag blades for quick return to review
- Adjustable torque limit to 150 ft-lbs (203 Nm)—the most torque available from any turnover tool
- Most commercial and military engines loaded in engine library
- Motor is designed to fit all previous versions of Sweeney engine interface adaptors
- Automatic/manual modes
- Variable speed and pause interval.



## Benefits

- Reduces inspection time
- Improves accuracy in positioning turbines for inspection
- New motor control technology will allow unprecedented accuracy (0.006 degrees) in positioning blades
- Quick set up—integrated carry case is designed to hold the unit with all the cables attached — pull out the motor/adaptor and pendant and you are ready to go
- USB port on controller allows connectivity to laptops to download inspection reports for storage or print
- Pendant is lightweight and easy to use; it is shaped to fit in one hand or hung close by to be read by the operator
- Torque overload sensor shuts down operation if excessive torque occurs, which can protect expensive turbine components from damage
- Foot control for hands-free operation.



DTT motor installed on a gear box

Specifications	UOM	SWE189DTT
Total system weight	lbs	35
	kg	15,9
System container dimensions	in	10 x 18 x 24
	mm	254 x 457 x 610
Power input	Vac	85 – 260
	Hz	47 – 440
	W Max	200
Speed		Continuously variable from 20 degrees/min to 360 degrees/min
Direction		Bi-directional with backlash compensation adjustable by user
Torque		User selectable 30–150 ft-lbs (40.67–203 Nm)
Acceleration/deceleration		0,2 s minimum, 5 s maximum incrementally adjustable

The Sweeney portfolio includes turning tool adaptors for all models in the engine families listed below. If there is an adaptor requirement for an engine model not listed, engineers will work with you to design a customized solution.

**CFM56**  
*LEAP is in development*

**V2500**

**GE**

- GE90
- GenX
- CF6
- LM2500
- LM5000
- LM6000
- F110

**Pratt & Whitney**

- JT8D
- JT9D
- PW2000
- PW4000

**Rolls-Royce**

- AE2100
- RB211
- Trent



# Military Ground Support Equipment & Custom Tooling

The machining technology in our Antigo, WI manufacturing facility supports custom tooling solutions on multiple aircraft models used by the US Military.

Standard and digital torque multipliers are the core products, but capabilities extend to:

- Fixtures for removing and dismantling engines or transmissions
- Hoists for helicopter rotor blade removal in the field
- Lifts and handling kits for propeller removal and installation
- Shop stands for engine and transmission storage or transportation
- Custom sockets, adaptors, base plates and retaining nuts.

Sweeney tools are used to support the following:

- High-torque requirements for turbofan engines:
  - Pratt F100 on the F-15 and F-16
  - GE F110 on the F-16
  - GE F404
- Propeller removal assemblies on turboprop engines:
  - T56 on the C-130, E-2, & P-3 Orion
- Ground support equipment and torque tools for:
  - T55 on the CH-47 Chinook
  - T64 on the CH-53
  - T700 on the Apache & Black Hawk
- Custom “make-to-print” tool kits for maintenance on new or legacy engines

## Sweeney Primary & Secondary NAICS Codes

332710: Machine Shop – Aircraft Maintenance Fixtures  
332216: Manufacturing - Hand Tools, Non-Edged, Non-Powered  
336413: Aircraft Ground Handling & Servicing Equipment  
333991: Power Driven Hand-Tools

## Primary FSC Codes

1730: Aircraft Ground Support Equipment  
4920: Aircraft MRO Equipment  
5120: Hand Tools, Non-Edged, Non-Powered

For a list of active NSN's, please contact your local representative at [aero@enerpac.com](mailto:aero@enerpac.com)

Sweeney CAGE Code: 87641  
DUNS: 557305146



SWE13750 Tower Hoist



SWE8271 Lift in use



Engine stand

**Full service and calibration is offered for many models of torque wrenches including all Enerpac and Sweeney torque wrenches and torque testers.**

Most torque tools have an industry standard recommendation of a yearly calibration cycle. Recommendations are to send your tools in on an annual basis to be certified and serviced.

Our repair center offers:

- Full service inspection, lubrication and certification
- NIST traceable as found and as left paper certificates provided with each service
- Quick turnaround time
- Expedited service available (48–72 hours) upon request
- Repair estimates provided before service

## Repair Facilities

### USA

Enerpac Repair  
2010 Clemont St  
Antigo WI 54409 USA  
Tel: +1 715-627-5521  
Fax: +1 715-627-5554  
[us.repair@hydratight.com](mailto:us.repair@hydratight.com)

### Japan

Yokohama Engineering Service Ltd,  
3435-1 Ikebe-cho, Tsuzuki-ku,  
Yokohama 224-0053 Japan  
Tel: +81-45-929-2577  
Fax: +81-45-937-6636  
[minoru.yamanaka@yes-yokohama.com](mailto:minoru.yamanaka@yes-yokohama.com)  
<http://www.yes-yokohama.com>

### United Kingdom

Turbine Tools Ltd.  
Unit K Sheddingdean Business Centre  
Marchants Way  
Burgess Hill  
West Sussex RH15 8QY  
Tel: 01342 716600  
[www.turbinetools.co.uk](http://www.turbinetools.co.uk)  
[www.facebook.com/turbinetools](https://www.facebook.com/turbinetools)



Enerpac is a global market leader in high pressure hydraulic tools, controlled force products, portable machining, on-site services and solutions for precise positioning of heavy loads. As a leading innovator with a 110-year legacy, Enerpac has helped move and maintain some of the largest structures on earth. When safety and precision matters, elite professionals in industries such as aerospace, infrastructure, manufacturing, mining, oil & gas and power generation rely on Enerpac for quality tools, services and solutions.

**110**  
years of history

**~2600**  
employees

**90+**  
countries

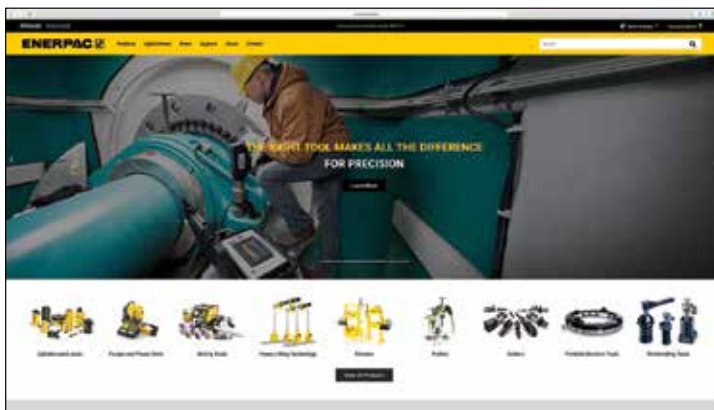

**www.enerpac.com** for latest Enerpac information

- Learn more about hydraulics
- Promotions
- New products
- Electronic Catalogs
- Trade shows
- Manuals (instruction and repair sheets)
- Nearest Distributors & Service Centers
- Enerpac products in action
- Heavy Lifting Technology

### Ordering Products and Catalogs

To find the name of the closest Enerpac distributor or service center, to request literature or technical application assistance, contact Enerpac at: [enerpac.com/contact-us](http://enerpac.com/contact-us)

### Bolting Tools



### Cylinders, Lifting Products & System



### Pumps & Directional Control Valves



### System Components & Control Valves



### Presses



### Pullers



### Tools



### Heavy Lifting Technology





# **SWEENEY** **AIRCRAFT ASSEMBLY & MAINTENANCE TOOLS** **COMMERCIAL & MILITARY**

## **Torque Multipliers**



Model SWE8200/SWE8200DS



Model SWE8112



Model SWE8510D/SWE8550D



Turbine Engine Digital Turning Tool



Military Ground Support  
Equipment & Custom Tooling



Model SWE8202A  
with Model SWE8300